

CONTACT PRINCIPLES

THREE POSITION, ROTARY PUFFER STYLE

For systems through 35kV, 630A continuous current with 40kA asym. momentary, 32kA asym. close into fault, and 25kA sym. one second current; rotary puffer (RP) style switches are used. G&W's multi-position spring operator permits an integral third switching position to increase the application capability over conventional two position switches. Three position switches combine increased switching flexibility with compact construction.

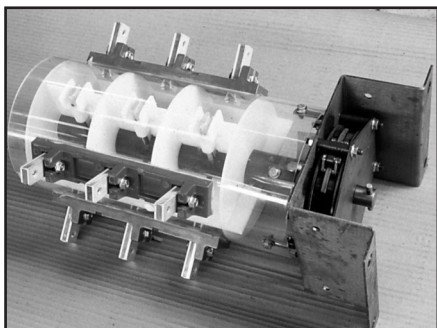

▲ Three position rotary puffer mechanism.

THREE POSITION, ROTARY PUFFER CONTACT PRINCIPLE

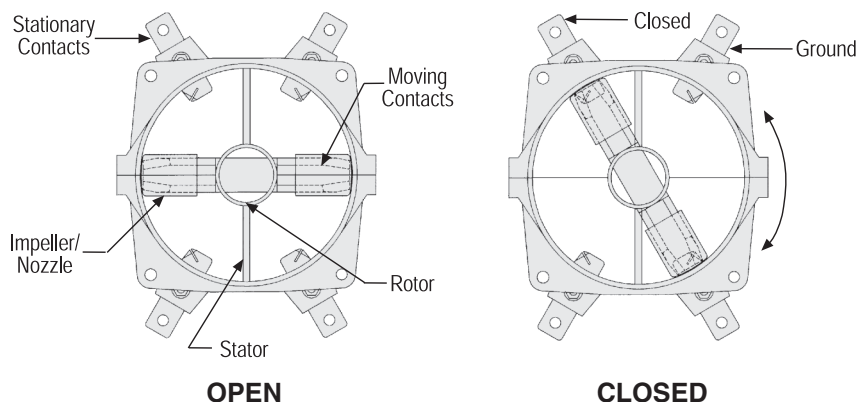

A. The stationary contacts and the multi-chamber rotor (an assembly of interlocking parts which form a rotational framework including moving contacts) are housed in a clear cylindrical shell. The stationary contacts are supported independent of the cable entrance bushings, eliminating possible misalignment resulting from tank deflections. Tank deflections are caused by normal tank pressure variance due to ambient temperature fluctuations. Each rotating contact simultaneously disengages from two stationary contacts, providing two break points per phase. This provides improved interrupting capability as compared to single break contact systems.

B. As the rotor tube assembly turns to disengage the moving contact from the stationary contacts, dielectric media (SF_6 gas) is compressed between the impeller and stator. The shell, phase barrier and rotor tube also act to confine the gas for proper compression and flow. The compressed SF_6 gas is directed through the nozzle into the arc zone. The SF_6 flows (is puffed) across the contacts and around the arc established by the separating contacts, cooling the arc over the length of the nozzle. The cooling action is increased by the higher pressure (due to compression) and the flow of gas which constantly provides a supply of cool SF_6 into the arc zone.

C. At current zero, the temperature of the arc is reduced to the point of deionization. The SF_6 gas rapidly recovers dielectric strength withstanding the system recovery voltage and preventing re-ignition of current across the contacts.

D. As the rotor tube assembly turns to engage the moving contact with the stationary contacts, the impeller induces a flow of SF_6 gas between the contacts to minimize pre-strike.