



Engineered to Order
Built to Last

GIS and Oil Immersed Transformer Terminations

69kV - 245kV

G&W's PATR style transmission terminations are designed for gas insulated substation and oil immersed equipment applications on extruded dielectric cable systems rated 69kV to 245kV. G&W has been a leading supplier of innovative cable accessory solutions since it was founded in 1905. With installations and sales representation worldwide, G&W continues to offer the latest technology products with world-class, time proven performance. G&W is ISO 9001:2000 registered for its quality systems. G&W offers a wide variety of terminations and joints for all types of cable construction through 500kV.

FEATURES

- Mechanical shrink stress cone permits fast installation without special tools. Simply position the cone and pull out the plastic core tab. It's that simple.
- Field proven, time proven reliability, with installations world wide.



Shown with contact pad, aluminum entrance housing and heat shrink seal.



▲ Mechanical shrink stress cone



▲ 145kV terminations being prepared for installation in a gas insulated substation

GIS and Oil Immersed Transformer Terminations

69kV - 245kV

For extruded dielectric cables from 240-2500mm² (500-5000kcmil).

STANDARD COMPONENTS

- 1) Equipment connection:
 - Contact pad style suitable for GIS or oil immersed transformer applications
 - Stem connector style suitable for oil immersed transformer applications. Various styles of aerial lugs are available for stem connector design. (See page 3)
- 2) Epoxy insulator with built-in cable shield break
- 3) Mechanical shrink stress cone
- 4) Dielectric fluid
- 5) Connector with double "O"-ring seal
- 6) Aluminum base plate
- 7) Aluminum clamping ring
- 8) Aluminum entrance housing with heat shrink seal
- 9) Cable preparation kit includes: grease, sandpaper, PVC tape, heat shrink seal, solder, flux, tinned copper ground braid and grounding lugs.

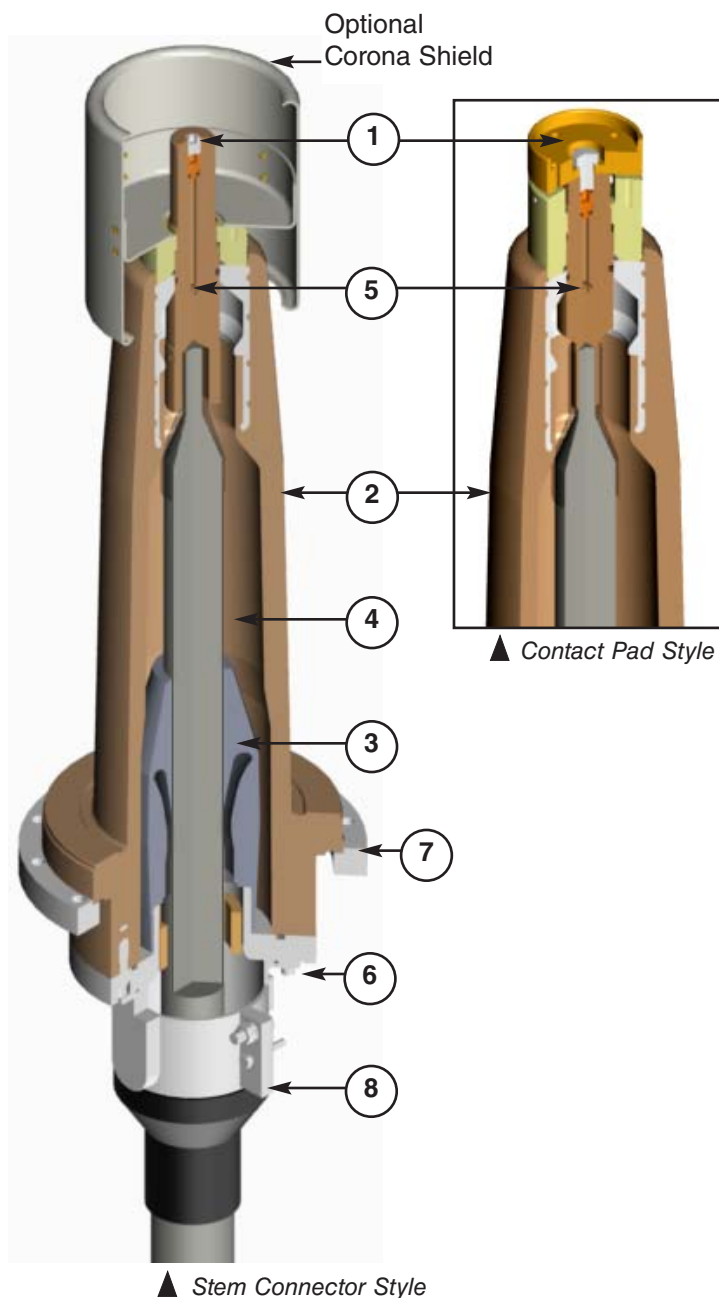

OIL FILLING KIT

- Required for filling terminations during installation
- Kit must be ordered separately
- Kit can be used to fill multiple terminations. G&W recommends ordering one oil filling kit per six terminations ordered.
- Supplied with:
 - Pump
 - Valves and fittings
 - Hose (2 meters)
 - Sight glass

Style 4 Clamp Type					
Aerial Conductor Size		Aerial Lug Height Dimension		Lug Material	Code
mm ²	AWG/kcmil	inches	mm		
35-240	#2 - 500	7	178	Bare Copper	C1
				Tinned	C1T
				Silver Plated Copper	C1S
300-500	550 - 1000	7	178	Bare Copper	C2
				Tinned	C2T
				Silver Plated Copper	C2S

Style 8 NEMA 4-Hole Type	
Code	Description
N	Bare Copper
NT	Tin Plated Copper
NS	Silver Plated Copper

Connectors

Termination	Conductor Material	Cable Size		Connector Style	Connector Material and Finish
		mm ²	kcmil		
Stem Connector	Copper	2500 max	5000 max	Crimp	Unplated Copper
	Aluminum	800 max	1600 max	Crimp	Tinned Aluminum
		Above 800	Above 1600	Migweld	Unplated Aluminum
Contact Pad	Copper	2500 max	5000 max	Crimp	Silver Plated Copper
	Aluminum	630 max	1250 max	Crimp	Silver Plated Aluminum
		Above 630	Above 1250	Migweld	Bi-metallic

Cable Entrance Options

Description	Code
Aluminum entrance housing and heat shrink seal	X
Bronze wiping sleeve	WS

Installation Method

Description	Code
Mechanical Shrink	X
Slip On- Use for spares or long term storage. Installation tool is available and is ordered separately	S

Dielectric Fluid Volume Compensating System

- Required for proper performance in horizontal or inverted terminations installations
- Compensates for dielectric fluid expansion and contraction caused by temperature fluctuations
- Supplied with:
 - Dielectric fluid reservoir with internal gas bladder
 - Insulating hose
 - Optional alarm device to signal accidental loss of dielectric fluid
- Contact your G&W sales representative for additional information

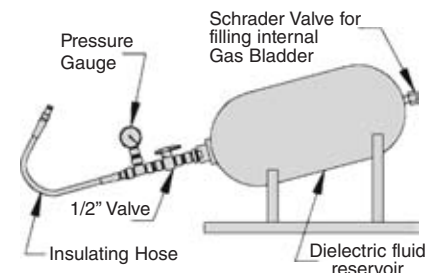

Catalog Prefix	Max Cable Insulation Diameter	Approximate Ship Weight
PATR119	93 mm (3.60 in.)	72 kg (160 lbs)
PATR140	87 mm (3.43 in.)	90 kg (200 lbs)
PATR160	107 mm (4.20 in.)	177 kg (390 lbs)

CATALOG NUMBER

Use the chart below to build your G&W catalog number. This number should be used for all inquiries and quotation requests. In addition, the following cable information is required to process your order:

1. Conductor size and O.D. of conductor (nominal and max)
2. Insulation O.D. (min and max)
3. Insulation shield O.D. (min and max)
4. Jacket O.D. (nominal and max)
5. Cable construction details with metallic screen type and fault current rating

PATR140 - SF - CS - 630M A - WS - C2 T - X



1 System Voltage

Rated Voltage kV (IEC)	Rated Voltage (kV) IEEE	BIL (kV)	Code
72.5	69	350	PATR119
138	145	650	PATR140
230	245	1050	PATR160

2 Connection Type

Description	Code
Stem Connector	X
Contact Pad per IEC 62271-209, 60859	SF

3 Corona Shield Option

Description	Code
None	X
Corona Shield	CS

4 Conductor Size (Contact G&W for additional cable sizes)

Cond. Size mm ²	Code	Cond. Size kcmil	Code
240	240M	500	500K
300	300M	750	750K
400	400M	1000	1000K
500	500M	1250	1250K
630	630M	1500	1500K
800	800M	1750	1750K
1000	1000M	2000	2000K
1200	1200M	2500	2500K
1400	1400M	3000	3000K
1600	1600M	5000	5000K
1800	1800M		
2000	2000M		
2500	2500M		

5 Conductor Material

Material	Code
Copper	C
Aluminum	A

6 Entrance Configuration

Description	Code
Aluminum entrance housing and heat shrink seal	X
Wiping Sleeve for lead sheath, corrugated aluminum, or corrugated copper cable, Mounting plate with standoff insulators (4)	WS

7 Aerial Lugs (use only with stem connector)

Description	Code
No aerial lug	X
Clamp, Copper, 240mm ² max	C1
Clamp, Copper, 300mm ² - 500mm ²	C2
NEMA 4-hole, Copper	N

8 Aerial Lug Finish

Finish	Code
None	X
Tinned	T
Silver	S

9 Installation

Description	Code
Standard - Mechanical Shrink	X
Spares - Slip On	S

EXAMPLE 1:

PATR140-SF-X-630MA-WS-X-X

145kV termination with contact pad for 630mm² aluminum conductor with wiping sleeve, with standard, mechanical shrink installation.

EXAMPLE 2:

PATR140-X-CS-630MC-X-C1S-X

145kV termination with stem connector and corona shield for 630mm² copper conductor with clamp style, silver plated aerial lug, with standard, mechanical shrink installation.