

ACCESSORIES AND OPTIONS

VACUUM INTERRUPTER OPERATION

The overcurrent control monitors the current and sends a trip signal which opens the vacuum interrupters and interrupts the fault current. The control is self-powered from the current transformers located inside the sealed switch tank. The user selects the time-current curve (TCC) desired. External trip and power connections are available as an option.

CONTROL ENCLOSURES

Standard control enclosures are NEMA 4X (IP56) rated and are hard-wired with 25 feet of cable for mounting remotely where the enclosure will not be immersed. Optional submersible enclosures are NEMA 6P (IP67) rated.

INTERRUPTER CONTROL OPTIONS

Type 1 controls operate three, single phase vacuum interrupting mechanisms. The Type 1 can be field set for either single phase or three phase trip mode. It is used on switches with either single phase reset or three phase reset. When in the three phase mode, all three phases trip if the selected trip level of any individual phase is reached. Trip level selections can be made under load or no-load conditions with current ranges in 12 selectable levels. Two ranges of minimum trip settings are available, 15 to 300 amps and 30 to 600 amps. Each unit is preprogrammed with multiple TCCs. The curve selection can be set or changed at any time.

An 8 pole dip switch allows the user to choose the TCC that best matches their individual coordination requirements. A label, located on the inside of the lid, provides a key for the dip switch settings. The control can be factory preset to meet the user's requirements. As protection or coordination requirements change, settings can easily be changed in the field. Depressing the manual trip but-

ton when the control is powered up electronically trips all three phases of the vacuum interrupter. Each control also includes "Last Cause of Trip" LEDs. These LEDs indicate which phase experienced an overcurrent condition, or that the control was given an external or manual trip command.

Type 2 controls offer features similar to Type 1 with the following exceptions:

- Three phase protection only
- Minimum trip set for all three phases with one selector switch
- Adjustable phase time delay
- Ground fault (phase imbalance) with separate adjustable time delay selector switch for protection of large three phase motors or transformers. The ground trip level is represented as a percent of the minimum trip level.
- Instantaneous trip and inrush restraint features

Type 3 controls offer features similar to Type 2 and more including:

- Single phase or three phase trip
- Vacuum fluorescent display
- Keypad operation for programming parameters and retrieving status of current values
- Multiple TCC curve capability
- Adjustable phase time delay
- Ground fault trip
- Inrush restraint
- Phase identification and magnitude of fault indication
- Readout of real-time current values
- Selectable instantaneous trip
- Selectable minimum response time
- RS232 or RS 485 serial interface
- Laptop programming kit available

Type 4 controls provide the same features as Type 3 however, there is no keypad panel, display screen, or



▲ Standard Type 1 control

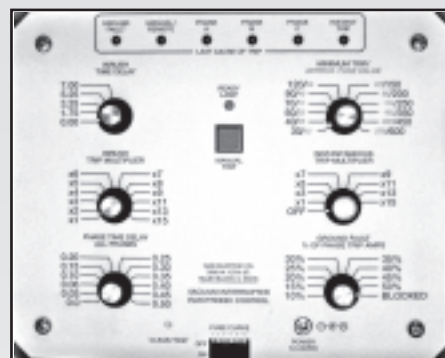

▲ Optional Type 2 control



▲ Optional Type 3 control



▲ Optional Type 4 control

manual trip button. The electronics are mounted external in a separate enclosure. The control is programmed using a laptop computer.

ACCESSORIES AND OPTIONS



3-1/C, 600A QUIK-CHANGE DISCONNECTABLE BUSHINGS

Cable entrance bushings can be damaged at any time due to improper handling, accidental shifting during shipment, elbow failure or even normal wear and tear. In the case of SF₆ gas insulated switches where the tank is totally welded, conventional bushing replacement means sending the switch back to the factory for repair. G&W's exclusive Quik-Change Disconnectable Bushing permits quick, easy field replacement without having to open the switch tank.

Bushings are designed to ANSI/IEEE 386 standards with standard interface accepting conventional elbow style connectors and include an aluminum conductor with 5/8"-11 aluminum threaded stud and aluminum single hole pad (**elbows must be ordered separately**). Copper studs are available. For bottom entry switches, recommended switch frame height is 42" for all voltages.

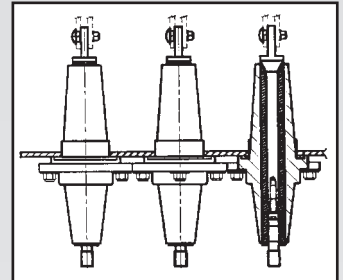

kV	Amp	kV BIL	Wt./3Ø set lbs (kgs)
15	600	110	25 (11)
25	600	125	25 (11)
35	600	150	35 (16)



3-1/C, 600A VOLTAGE SENSING BUSHINGS

Voltage sensors are required for automatic transfer or distribution automation schemes. Sensors are typically add-on devices and can be cumbersome to wire and install. G&W's Voltage Sensing Bushings incorporate a capacitive voltage screen built directly into the epoxy bushing to provide a clean, precise solution capable of installation and testing at the factory. Other advantages include:

- Submersible construction
- Eliminates the need for capacitive test point elbows
- Precise, consistent readings compared to plug-on type devices
- Field calibration
- Provides one analog output per phase for voltage monitoring
- Provides one digital output per way for threshold voltage detection

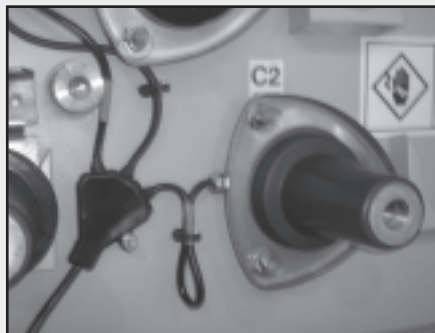

G&W's voltage sensing bushing measures line-to-ground voltage applicable for wye systems through 27kV. For DELTA systems consult your G&W representative. The voltage signal is accurate to +/-5% over the temperature range of -40°C to +65°C. The signal is transmitted through a single conductor cable extending from each bushing. A three phase bushing configuration would comprise of three single conductors (one from each bushing) terminated into a small potted junction box with a single multi-conductor cable extending out to a user accessible NEMA enclosure containing terminal connections for the automatic transfer or RTU control.

Bushings are designed to ANSI/IEEE 386 standards with standard interface accepting conventional elbow style connectors and include an aluminum conductor with 5/8"-11 aluminum threaded stud and aluminum single hole pad (**elbows must be ordered separately**). Bushings are bolt-on style. Copper studs are available. For bottom entry switches, recommended switch frame height is 42" for all voltages.

kV	Amp	kV BIL	Wt./3Ø set lbs (kgs)
15	600	110	25 (11)
25	600	125	25 (11)

ACCESSORIES AND OPTIONS



3-1/C, 600A APPARATUS BUSHINGS

Bushings are designed to ANSI/IEEE 386 standards with standard interface accepting conventional elbow style connectors and include an aluminum conductor with 5/8"-11 aluminum threaded stud and aluminum single hole pad (**elbows must be ordered separately**). Copper studs and welded flange bushings are available. For bottom entry switches, recommended switch frame height is 42" for all voltages. Welded flange bushings are available.

kV	Amp	kV BIL	Wt./3Ø set lbs (kgs)
15	600	110	25 (11)
25	600	125	25 (11)
35	600	150	35 (16)

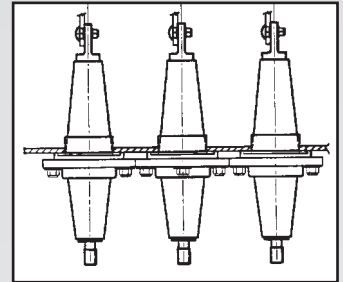

3-1/C, 200A DEEPWELL BUSHINGS

Bushings are designed to ANSI/IEEE 386 standards with standard interface accepting deadbreak or loadbreak inserts and conventional elbow connectors (**inserts and elbows must be ordered separately**). A copper conductor with copper single hole pad is standard. For bottom entry switches, recommended switch frame height is 42" for all voltages. Welded flange bushings are available.

kV	Amp	kV BIL	Wt./3Ø set lbs (kgs)
15	200	110	20 (9)
25	200	125	20 (9)
35	200	150	30 (14)

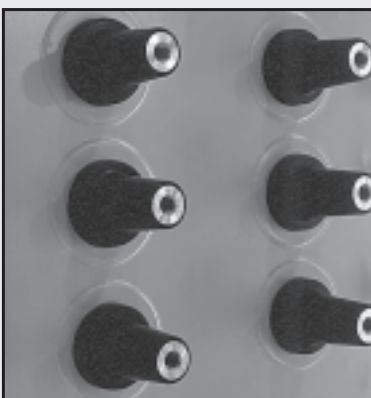
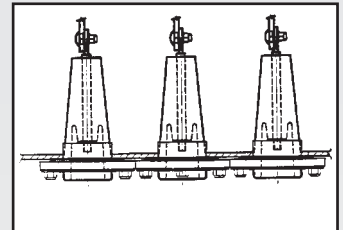

3-1/C, 600A APPARATUS BUSHINGS WELDED FLANGE STYLE

Bushings are designed to ANSI/IEEE 386 standards with standard interface accepting conventional elbow style connectors. Bushings include a stainless steel flange and an aluminum conductor with 5/8"-11 aluminum threaded stud. **Elbows must be ordered separately**. 200A deepwell welded flange available.

kV	Amp	kV BIL	Wt./3Ø set lbs (kgs)
15	600	110	20 (9)
25	600	125	20 (9)
35	600	150	30 (14)

ACCESSORIES AND OPTIONS



3-1/C, 600A UNIVERSAL BUSHINGS

The Universal Apparatus Bushing can be installed on virtually any type of padmount or submersible equipment providing a direct connect point for the U-Splice module. The combination U-Splice and apparatus bushing provides an extremely versatile interface between cable and equipment for easy connecting, disconnecting, and isolating of distribution cable circuits.

Straight-in or 90 degree cable entry to equipment provides versatility important for applications with a minimum of space available. End caps for both bushing and splice module permit dead-ending of the cable and equipment for fast cable sectionalizing if required.

Universal bushings are designed to accept G&W universal bushing cable ends (**G&W Universal bushing cable ends are not included and must be ordered separately. See chart below**). An aluminum conductor and aluminum single hole pad is standard. For bottom entry switches, recommended switch frame height is 36" for all voltages. Hi-pot test kits are available.

NOTE: Universal bushings can accept up to two G&W Universal bushing cable ends per phase. For applications requiring this feature, consult factory.

kV	Amp	kV BIL	Catalog Number
15.5	600	110	UB376SF
27	600	125	UB386SF

UNIVERSAL BUSHING CABLE ENDS (PER PHASE)

For use with UB Type Switch Entrances
Complete cable data required before order can be processed.

Configuration	Catalog Number	
	15kV	25kV
Terminate 1 cable per phase	15CE	27CE
Terminate 2 cables per phase	15CE-CE	27CE-CE
Dead End Kit	15DCE	27DCE
Change 1 cable per phase to 2 cables per phase*	151V2	271V2

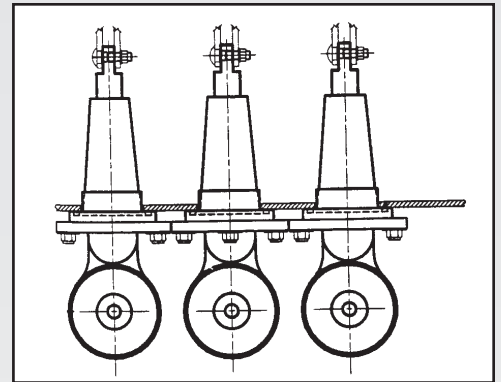

* Kit includes second cable end (CE) and hardware necessary for connection.

ACCESSORIES AND OPTIONS



3-1/C, 600A OPEN STUD BUSHINGS

Open stud bushings are furnished standard with 3/4"-16 threaded copper stud connectors and require G&W air termination kits (G&W air termination kits must be ordered separately. See below). For bottom entry switches, recommended switch frame height is 42" for all voltages where this bushing is used. If other than G&W termination kits are used, a NEMA 2-hole pad must be specified. See note below.

NOTE: 1. Bushings are also available with NEMA 2-hole pad. G&W air termination kits must be purchased separately. See below.

kV	Amp	kV BIL	Wt./3Ø set lbs (kgs)
15	600	110	35 (16)

AIR TAPE TERMINATION KITS

Tape termination kits include all material required for fully shielded air terminations. Specify by completing the catalog number below:

AT X X X X MR - Y Y - Z Z

XXXX = Conductor size, i.e. #4AWG (0004), 4/0 (04/0), 1000kcm (1000), etc.
 YY = Conductor type, i.e. Stranded Compressed (SC), Compact Round (CR).
 ZZ = Connector style, i.e. Aluminum Crimp (AC), Copper Solder (CS), Copper Crimp (CC).

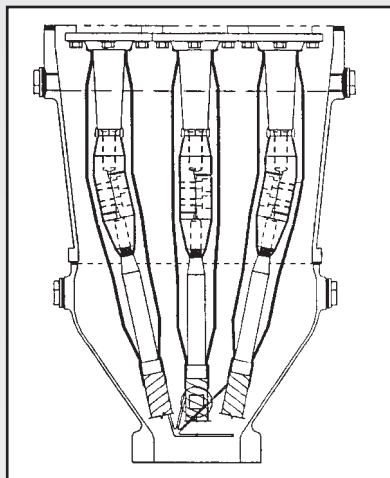
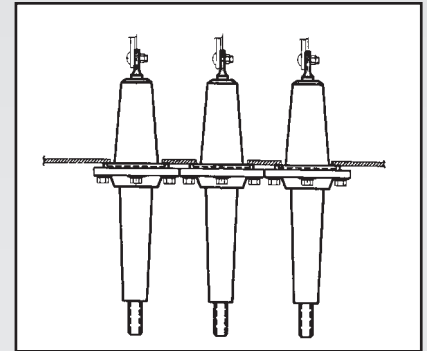

3/C, 600A STUD BUSHING COMPARTMENT

Stud bushing compartments include stud bushings with copper conductor, cast iron or non-magnetic cast aluminum mounting plate, shape C body and compartment, solder connector for copper conductors (aluminum conductors require compression style connectors), and WS, RS or DP entrances. Entrance style is dependent upon cable construction. Specify complete cable data when ordering. Accessory entrance fittings may also be required. Stud bushing compartments are designed for a maximum conductor size of 750KCM aluminum or 1000KCM copper. For bottom entry switches, recommended switch frame height is 60" for all voltages. **Stress cone kits and compound are required. Consult factory for proper compound selection.**

kV	Amp	Wt. lbs (kgs)	Comp'd Req'd gals (L)
15	600	140 (64)	5 (19)

STRESS CONE KITS

Conductor Size AWG/KCM (mm ²)	Catalog Number
4-4/0 (21-107)	T1MR
250-500 (127-253)	T2MR
600-1000 (304-507)	T3MR

Stress cone kits include all material required for fully shielded air terminations. Specify solder (copper) or compression (copper or aluminum) connector and complete cable data. Kits may differ depending upon cable insulation type.

ACCESSORIES AND OPTIONS

Refer to typical specifications pages for each switch style for standard components.

Gas Pressure Gauge and Fill Valve (Standard)

The pressure gauge is a "GO-NO-GO" style which is color coded to simplify verification of proper operating conditions. A Schraeder type fill valve permits refilling in the field. The gauge and fill valve are made of brass for corrosion resistance. Both components are protected by a steel guard.



▲ Pressure gauge and fill valve

Temperature Compensated Gas Density Gauge (Optional)

measures internal tank gas density for maximum precision of switch operating conditions. The gauge is colored coded to simplify reading by operating personnel.



▲ Temperature compensated gauge

Viewing Windows (Standard)

provide a means to visibly verify switch contact position. Single phase or three phase contact viewing is available.

Frames (Optional)

are corrosion-resistant galvanized steel channels and supplied factory assembled to the switch. Open or panel style frames are available in various heights.

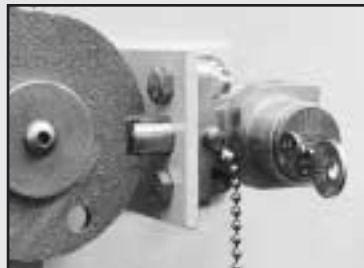

▲ Key interlocks

Key Interlocks (Optional)

may be used as an added safety measure to prevent operation by unauthorized personnel or to assure safe coordination of energized equipment. Switches can be provided with provisions only (two maximum per operating mechanism) or with keylocks factory installed. Specify locking scheme when ordering, i.e. lock in open, lock in closed or lock in both open and closed position. For keylocks to be coordinated with other equipment, manufacturer's information must be provided.

Ground Lugs (Optional)

are bronze, eyebolt style for 4/0 maximum conductor cable.

Auxiliary Switches (Optional)

can be mounted adjacent to each external operating mechanism to permit remote indication of switching position. One N.O. and one N.C. form C contact is provided for wiring by the customer. A maximum of two auxiliary switches can be installed per operating mechanism.

Low SF₆ Remote Monitoring

Device (Optional):

1) **Low Pressure Warning Devices** are factory set at 5 psig and permit remote indication of internal tank pressure. One N.O. and one N.C. form C contact is provided for wiring by the customer. **Recommended for installations where ambient temperature does not fall below 0°F (-15°C).**



▲ Low pressure warning device

2) SF₆ Density Switches

permit remote indication of internal tank gas density to assure proper pressure/temperature operating conditions. One N.O. and one N. C. form C contact is provided for wiring by the customer. **Recommended for installations where ambient temperatures fall below 0°F (-15°C).**



▲ Auxiliary switches



▲ SF₆ density switch

ACCESSORIES AND OPTIONS

OPTIONS

Select from the following options and add to the appropriate switch specification:

- Stainless steel tank
- Temperature compensated gas density gauge
- Low pressure warning device
- SF₆ density switch
- 4/0 brass ground lug
- Keylock provisions
- Keylocks to lock in open position
- Current transformers for current monitoring on automation schemes (600:5) (500:1) (1000:1)
- Potential transformers for voltage monitoring and/or control power
- Automatic transfer control
- Motor actuators for remote switch operation
- Auxiliary contacts for remote switch position indication
- Stationary switch controls for remote switch operation and SCADA integration
- DC portable switch controls for remote switch operation and SCADA integration
- Remote terminal units and communication packages for SCADA integration
- Operation counters
- 200A deepwell bushings
- 200A deepwell bushings with deadbreak insert
- 600A apparatus bushings
- 600A voltage sensing bushings
- 600A Quik-Change apparatus bushings
- 600A Universal bushings (through 25kV)
- Type 2 vacuum interrupter control
- Type 3 vacuum interrupter control
- Type 4 vacuum interrupter control
- External power / trip for vacuum interrupter control