

Subject: Overhead Auto Transfer with Overcurrent Protection

ISSUE

The vast majority of electrical service disturbances are on overhead circuits. Exposure to the elements, wildlife, and tree branches are all too common reasons why utilities implement solutions such as reclosers and automatic transfer controls to improve the inherent disturbances on overhead systems. Reclosers address transient problems while providing overcurrent protection. Automatic transfer controls maintain power in the event of a permanent feeder problem (such as a downed conductor) by essentially isolating faults and restoring power with an alternative, near-by utility source. Load break switches are used to do the transfer. But, what if the two sources are more than just a few hundred feet apart? What if overcurrent protection is needed?

SOLUTION

G&W Electric's robust VIPER reclosers and SEL's powerful 351R controls can now function in an overhead auto transfer application and still provide solid overcurrent protection. VIPER reclosers and their SEL 351R controls are positioned at the junction point for the preferred (or normal) source and at the alternate (or stand-by) source for the critical load(s). Refer to the system diagram. Potential transformers provide the sensing and control power while current transformers provide the inputs for the overcurrent protection.

When the preferred source voltage is lost (and there is no overcurrent present), the automatic transfer logic sends a signal to open the VIPER. Once the open position status is confirmed, a signal to close the alternate source VIPER is activated. Depending upon the

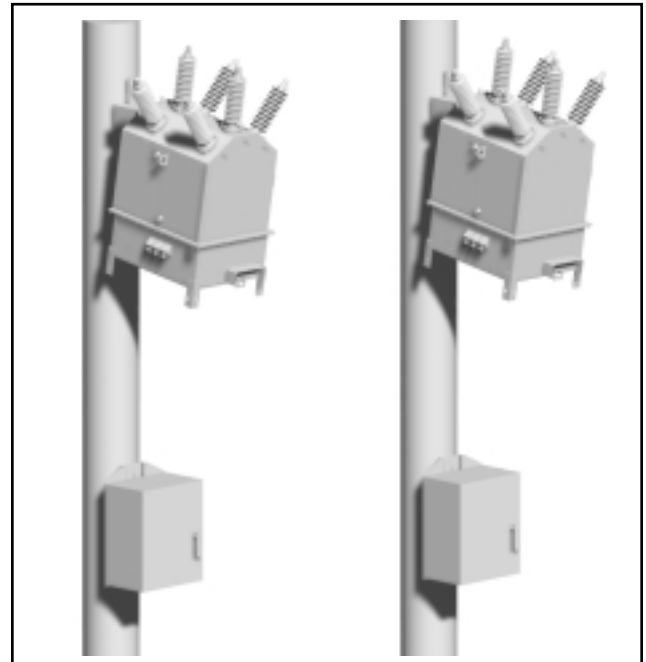

Distributed auto transfer using two overhead Viper reclosers, two SEL 351-R controls and fiber optic communications.

communication method selected, the total restoration time can be as little as 8 cycles*!

If an overcurrent is detected on the system, the 351R will engage its overcurrent protection logic and override the automatic transfer sequence. This gives the user the benefits of both recloser overcurrent protection and high speed automatic source transfer all in one package - a huge cost savings and a simplification to the number and variety of distribution system components.

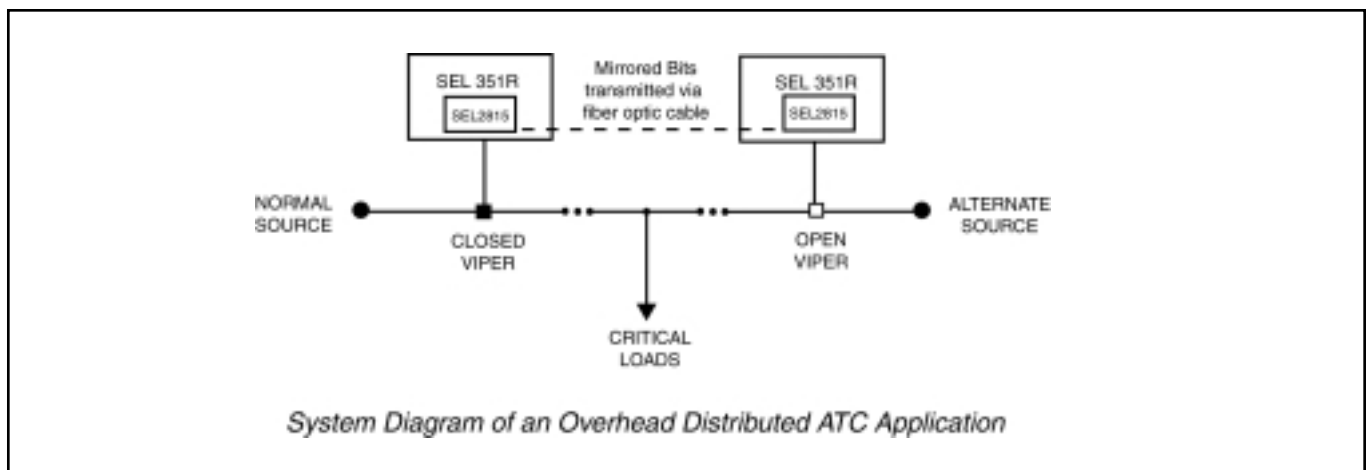

System Diagram of an Overhead Distributed ATC Application

FEATURES

- High Speed Automatic Transfer Switching with Overcurrent Protection.
- Distance between preferred and alternate sources is limited only by communication link selected.
- Over and Under Voltage, and Phase Angle.
- Synchronization Check.
- Directional Overcurrent Protection.
- Complete metering capabilities (Current, voltage, Power, Energy, Positive/Negative/Zero sequence voltages, frequency).
- Battery backup and sophisticated battery monitoring.
- SCADA inputs/outputs.
- DNP 3.0 available
- Total Restoration Time (using an Open before Close transition) in as little as 8 cycles*!
- Verification of switch status before operation eliminates the possibility of paralleling sources.
- User selection of transition sequence.
- Complete events recorder with time/date stamp
- Delay timers for initial and return transfer

* *Communication devices and transfer delay timers will effect the total restoration time.*

RATINGS

System Voltage, Max. kV.	15.5	29.238
Impulse Level (BIL) kV110125150
Continuous & Loadbreak Current, A630630	800
Interrupting Current, kA	12.5	12.5	12.5
Making Current, RMS asym. kA323232
Mechanical endurance, Operations	10,000	...	10,000	..	10,000

For more information, contact your local G&W Electric representative. To find your local representative, visit us at <http://www.gwelec.com>.